

EXTRUDED ALUMINIUM PROFILES

Let your ideas take shape with us

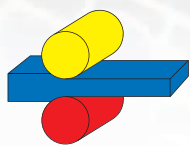

HARTMANN

www.hartmann-metalle.de

Complete solutions for extruded aluminium profiles

We provide high-quality services for extruded aluminium profiles in all kinds of sectors. From design, development and production to machining, packing and storage with sophisticated logistics, we offer an all-in service for the entire process chain. Thanks to our network of partnerships, you benefit from maximum flexibility and expertise at all times.

Consulting & design

Every product and every customer requirement starts with close consultation. During this phase, we analyse the best way to put your wishes into practice, presenting a comprehensive proposal tailored to your specific needs. This collaboration gives you a whole host of benefits such as an integrated technical approach, short delivery times and less administration.

BENEFITS

Planning, development & production – everything from a single source

Storage, packing & logistics

Plain, anodised or powder coated surface

Wide range of machining processes

Fixed lengths

From the smallest of cross-sections to large profiles

Special alloys

References & certificates

CE conformity & batch traceability

Extrusion

... is rather like squeezing toothpaste out of a tube. We order the die required to produce your aluminium profiles based on the profile drawing approved by you.

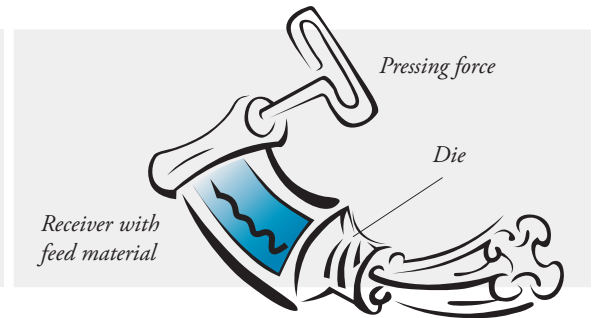

The outer limits ...

Pressing force	500 – 8000 t
Circumscribed circle	15 – 750 mm
Weight per metre	0,05 – 65 kg per m
Profile length	up to 14000 mm
Groups of alloys	1XXX, 3XXX, 6XXX, 7XXX
Surface finishing	RAL coating, anodising, chrome plating etc.

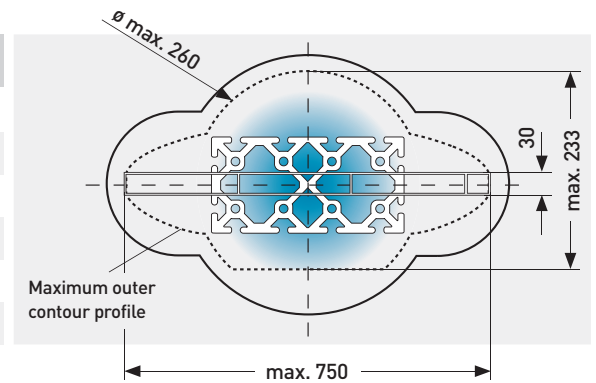

Versatile machining and finishing options

Problem-free further processing of your customised profile is then ensured, e.g.

drilling | punching | milling | cutting | deburring | bending | anodising | powder coating | grinding | foiling | etc.

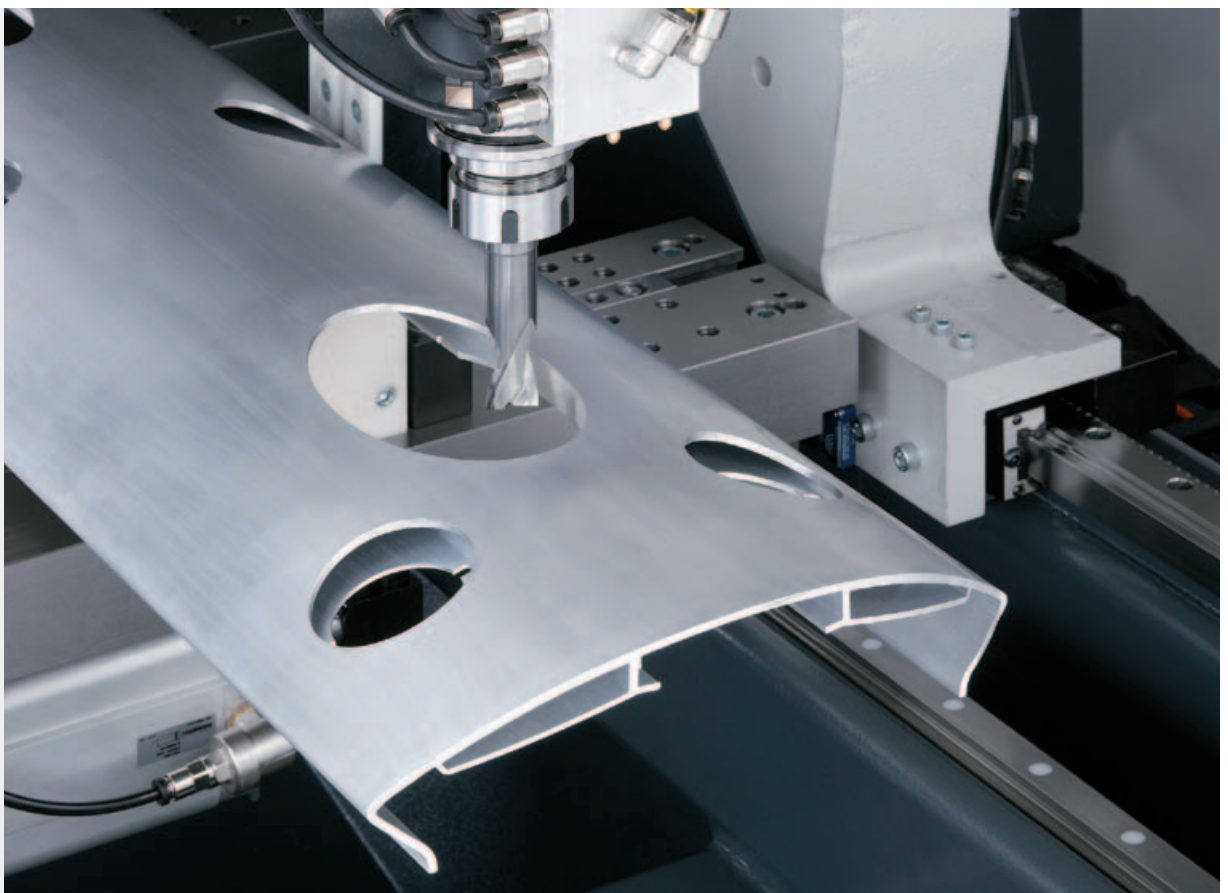

Product range – examples ...

Balcony profiles

Standard length 6000 mm in EN-AW - 6060 T66 (Al Mg Si 0,5 F22)

Handrail | LMS 7899

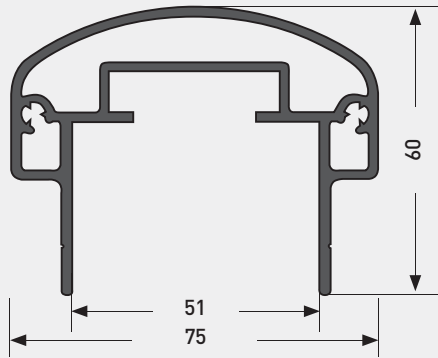

Border strip 8 mm | LMS 4052

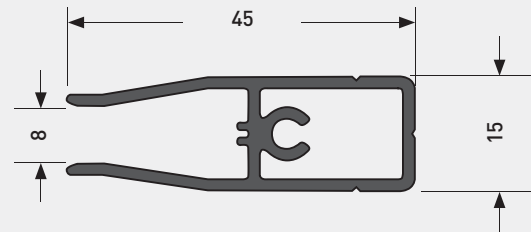

Profiles for illuminated signs

Standard length 6000 mm in EN-AW - 6060 T66 (Al Mg Si 0,5 F22)

LMS 06

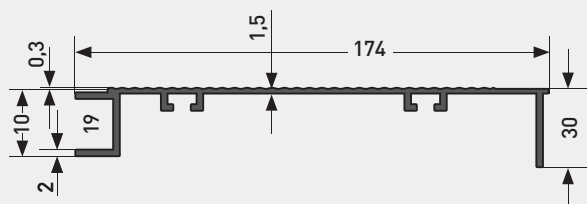

LMS 49

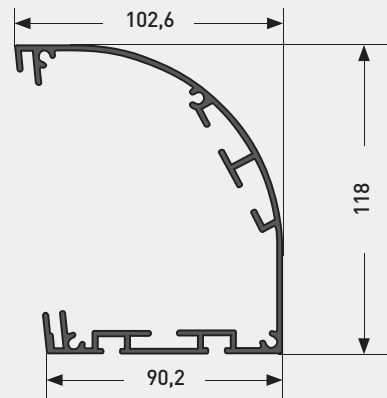

Groove-type butt connector for coping

Standard length 5000/6000 mm in EN-AW - 6060 T4 bendable

LMS 3318 | Bendable

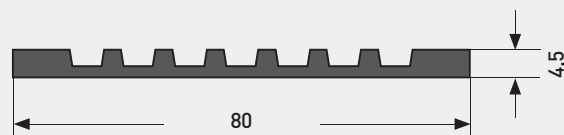

LMS 3319 | Bendable, perforated

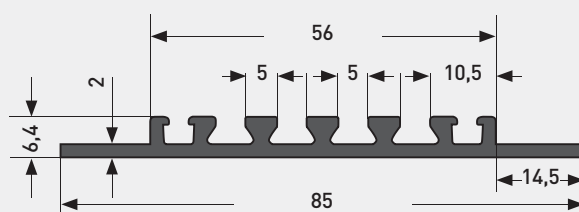

Sealing | LMS 3319/Dicht

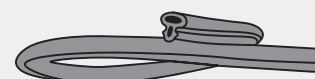

... For decorative applications

Extruded aluminium profiles are used for...



Conservatories

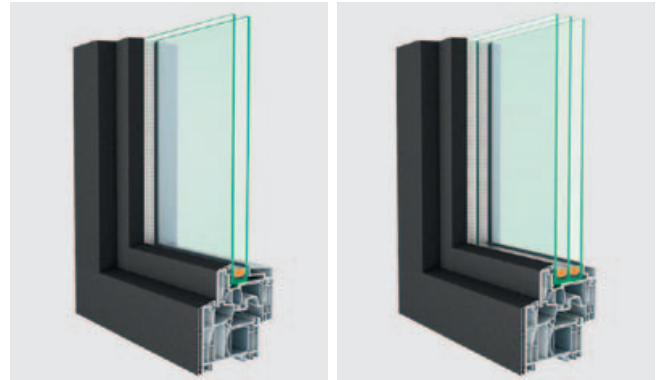

Plastic profile covers



Aluminium banisters

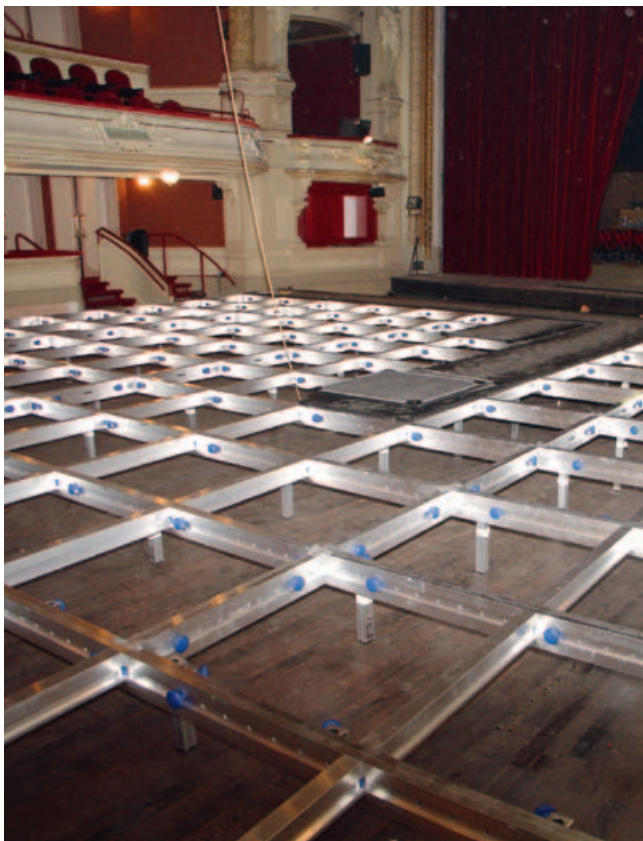

Theatre stages



Balconies

In addition to **extruded aluminium profiles**,
we stock many other aluminium semi-finished products:

termolac[®]

(powder-coated aluminium)



PVDF – fluoropolymer-coated
façade sheets

Aluminium in stainless steel look

Anodised sheets and coils

Mill finished sheets and coils

Patterned sheets

Standard profiles (Mill finished & coated)

Photovoltaics

... and many other non-ferrous metals

W. Hartmann & Co. (GmbH & Co. KG)
info@hartmann-metalle.de | www.hartmann-metalle.de

Möllner Landstr. 107
D-22113 Oststeinbek
Germany

Phone +49 (0) 40 71 30 24-61
Fax +49 (0) 40 71 30 24-49

Hornstraße 26
D-45964 Gladbeck
Germany

Phone +49 (0) 20 43 40 05-0
Fax +49 (0) 20 43 40 05-11

Benzstraße 5
D-89155 Erbach
Germany

Phone +49 (0) 71 35 93 77-36
Fax +49 (0) 71 35 93 77-57

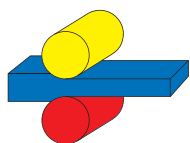

HARTMANN

www.hartmann-metalle.de

Semi-finished metals **1925**
SINCE